

THIS DRAWING IS UNPUBLISHED. RELEASED FOR PUBLICATION , 19

© COPYRIGHT 19

BY AMP INCORPORATED. ALL INTERNATIONAL RIGHTS RESERVED.

LOC	DIST	P	F	ZONE	LTR	REVISIONS		
						DESCRIPTION	DATE	APPD
AF	50				F	REDRAWN PER 0032-94	2/2/94	JR

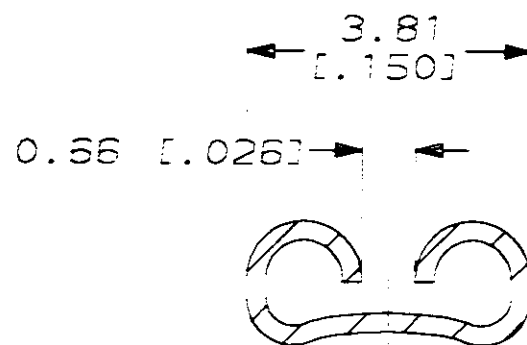
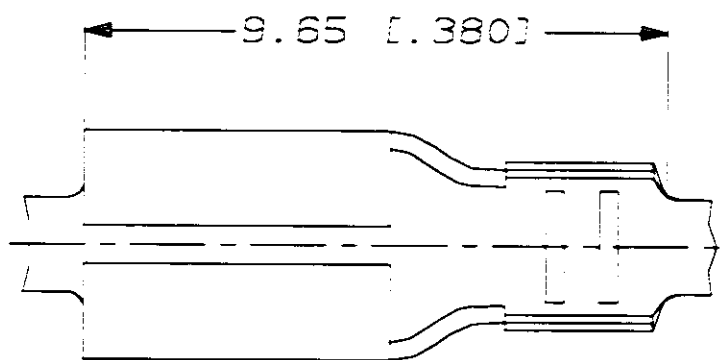

- 1 CONTINUOUS STRIP ON REELS
- 2 TIN OVER COPPER

SECTION A-A  
SCALE 10:1

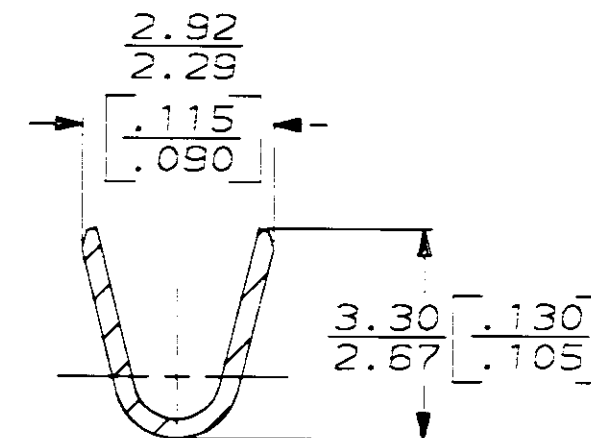
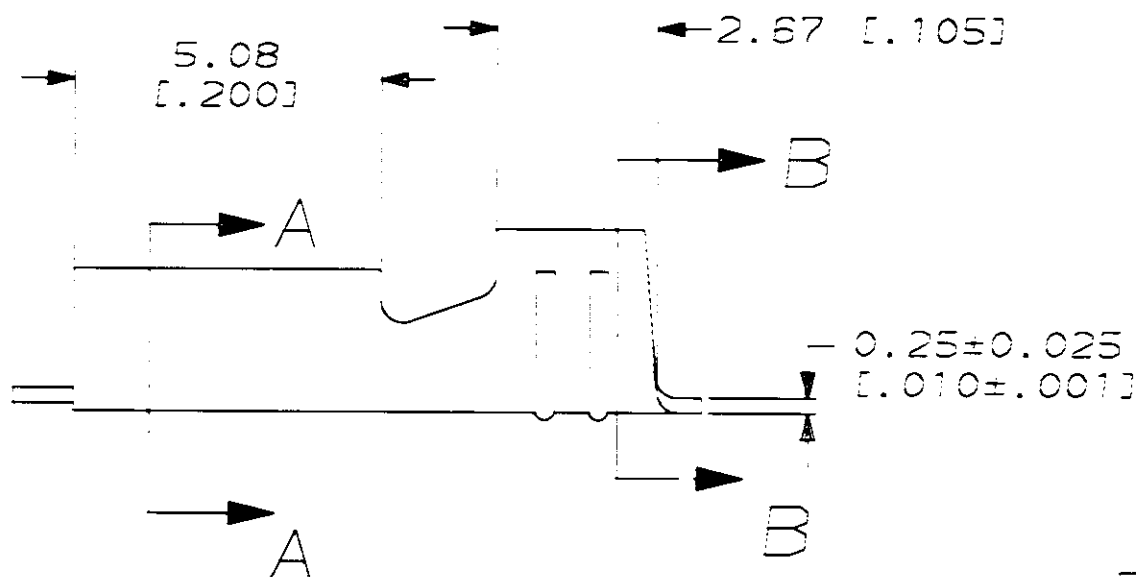

SECTION B-B  
SCALE 10:1

<b>2</b>	PRE-TIN	#20-#18 AWG	0.51 [0.020]	62850-2 62850-1
FINISH	WIRE SIZE	MATING TAB THK ±.001	PART NO	
DO NOT SCALE PRINT. UNLESS SPECIFIED. DIMENSIONS ARE IN MM (INCHES). TOLERANCES ON: 2 PLC DEC ± 0.38 [0.015] 3 PLC DEC ± - ANGLES ± -	DR 2/2/94 JR RUTH CHK 2/2/94 MS FEMER	AMP Incorporated Harrisburg, PA 17105-3608		
MATERIAL	APPD 2/2/94 P DESANTIS APPD 2/2/94 D REINER	NAME RECEPTACLE, FASTON, 2.79 [0.110] SERIES		
#4H BRASS	PRODUCT SPEC	SIZE	CAGE CODE	DRAWING NO
SEE TABLE	APPLICATION SPEC	<b>B</b>	00779	62850
	WEIGHT	SCALE	SHEET	
		8:1	1 OF 1	